

AVAYA

Avaya Experience Platform



The Everything Customer





“2 in 10 customers will walk away after a single bad experience. 6 in 10 will walk away after several bad experiences.”

Source: Ipsos research commissioned by Avaya



The Experience Economy

“A new economic era in which all businesses must orchestrate memorable events for their customers, and that memory itself becomes the product”

Pine and Gilmore





**3 in 4 millennials
choose to spend money
on experiences instead
of products”**

EventBrite



Create Experiences

- Customer Experience CX
- Employee Experience EX
- User Experience UX
- Multiexperience MX

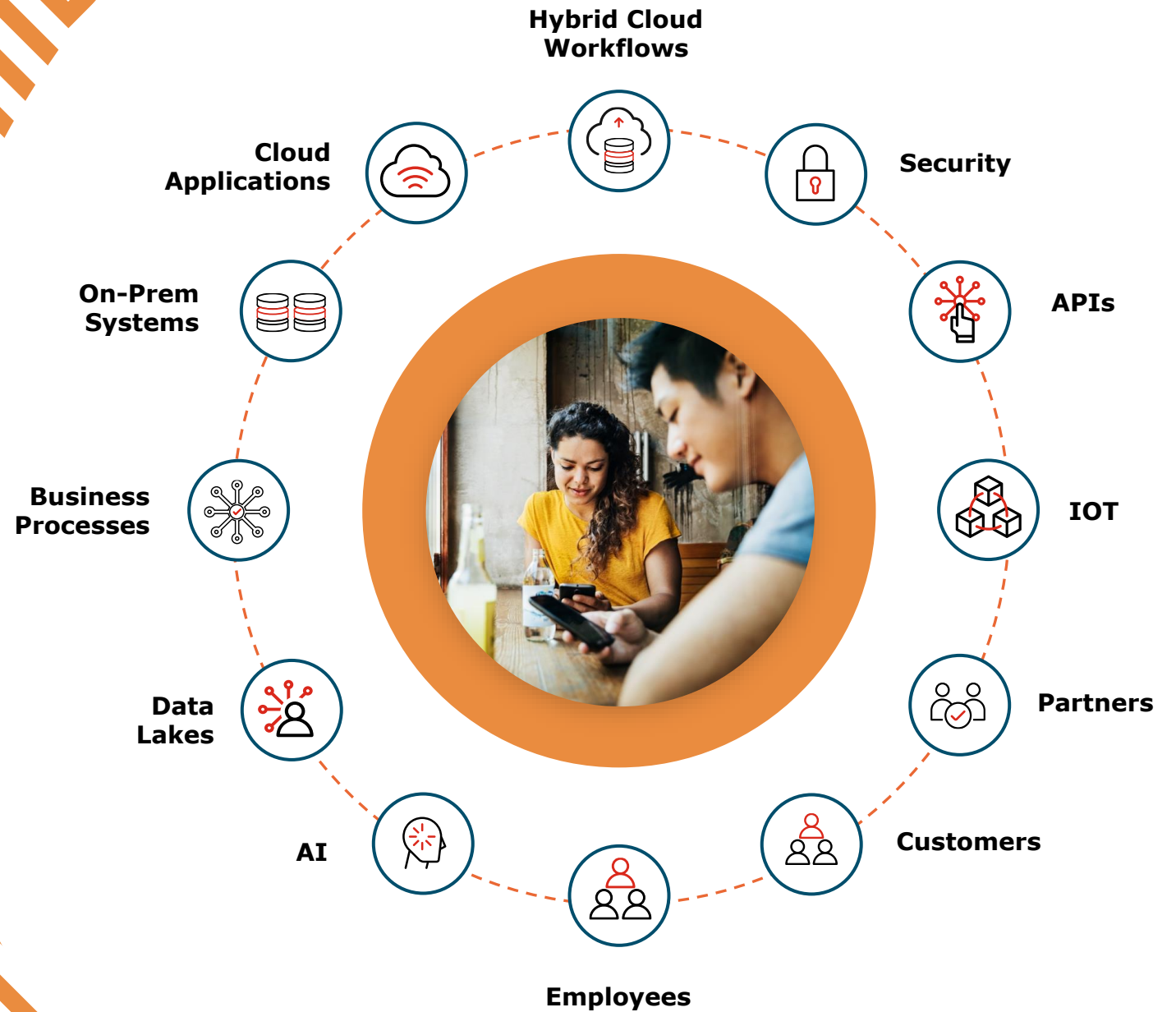

Monolithic to Composable Journey

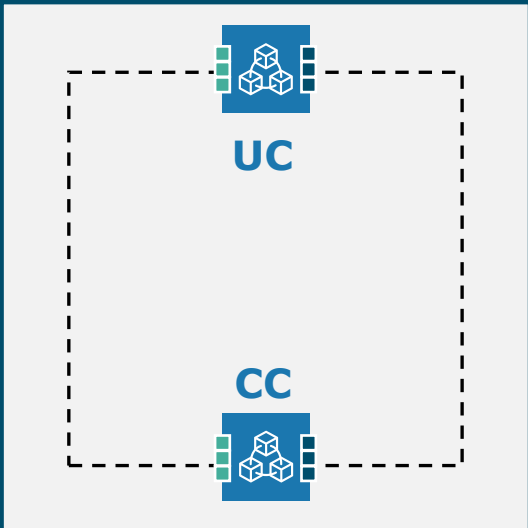

Monolithic Canned Applications

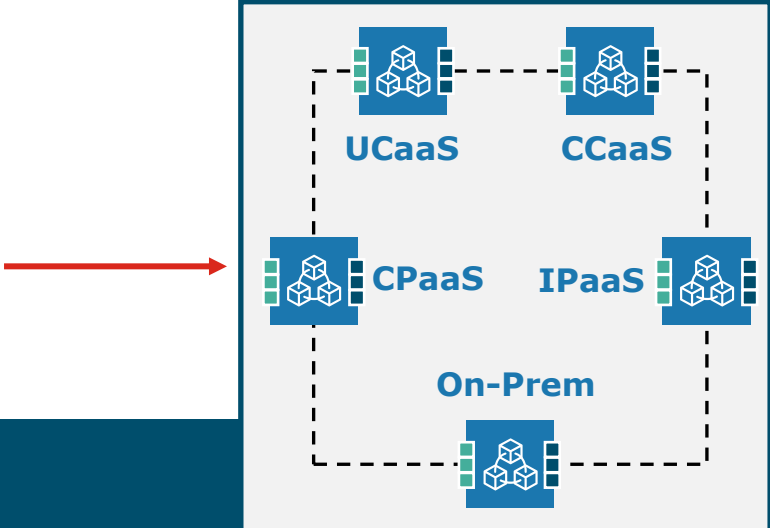

Some Extensibility Limited Total Experience Support

Compose seamless and effortless experiences across apps, touchpoints, modalities and personas.

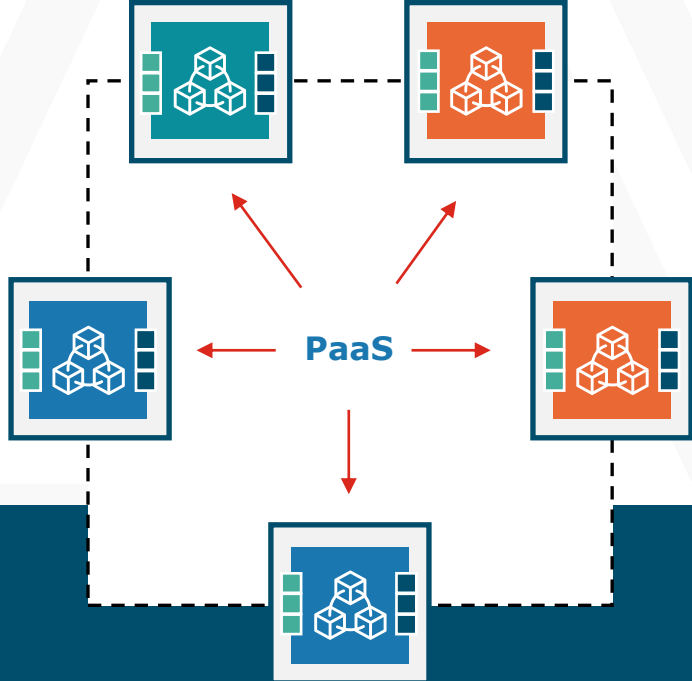

API-Economy Powered Composed Experiences

Avaya OneCloud™

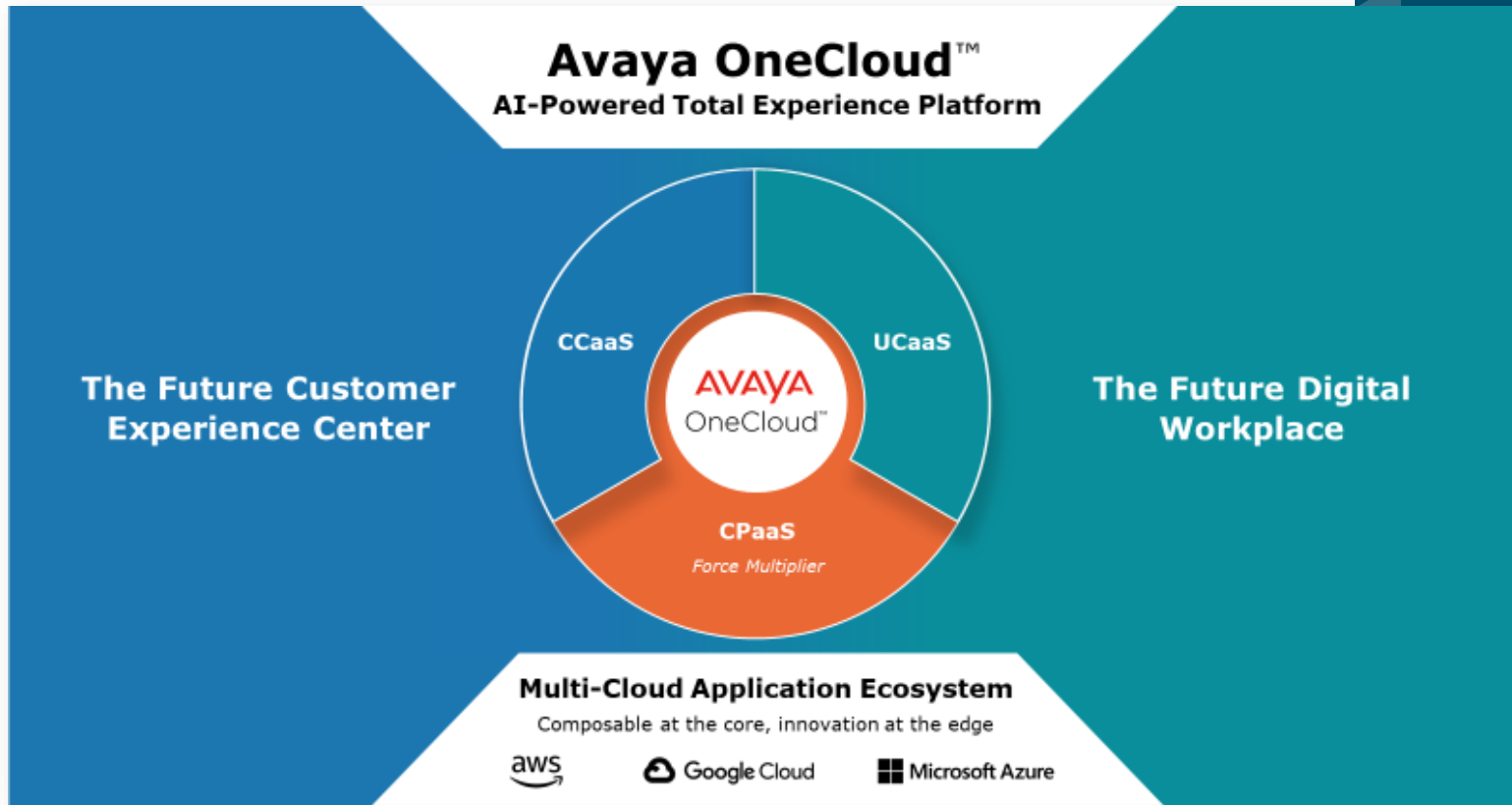
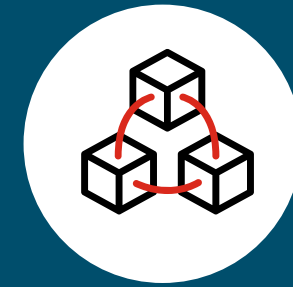

PLATFORM
Avaya OneCloud™

AI-Powered
Experience
Platform

“Award-winning!”



Customer Experience (CX)

Customer's perceptions and related feelings caused by one-off and the cumulative effect of interactions with supplier's employees, systems, channels or products



Employee Experience (EX)

Employee's perceptions and related feelings caused by one-off and the cumulative effect of interactions with employer's customers, partners, leaders, teams, processes, policies, tools and overall work environment.

The Total Experience

A strategy that connects multiexperience with customer, employee and user experience disciplines



Multiexperience (MX)

Interaction across variety of digital touchpoints using a combination of interaction modalities in support of seamless and consistent digital user journeys.



User Experience (UX)

Singular or aggregated experiences that occur for users from interacting with product in given context.

Avaya Experience Builders™

Reimagining Business Experiences



Avaya Experts

- Hybrid Cloud Services
- Omnichannel Services
- AI Powered Services

Pre-built frameworks and unique tools accelerate experience delivery and solve complex problems



Avaya Customers

- DevOps
- Fusion Teams
- Citizen Developers

Large global customer base empowered to achieve more



Avaya Partners

- Unified Communications
- Contact Center
- General Services
- General Management
- Custom Development
- Education
- Financial Services
- Government
- Healthcare
- Hospitality

Best in class capabilities / Broad geographic reach

Avaya Experience Builders™ – By the Numbers



250 technology partners

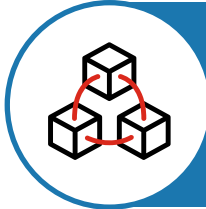

32,000 companies in
Avaya DevConnect



154,000 registered
developers

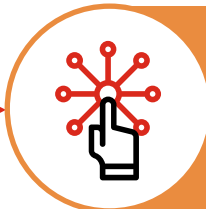

24,000 using Avaya
OneCloud™ CPaaS



9,000 channel partners
and agents

Wrap Your Business Around Each Customer... with Avaya

Avaya OneCloud™



Avaya Services



Tech Partners



Channel Partners



Customer Developers



Avaya Experience Builders™

AVAYA

| Experiences
That Matter

Let's Build It!

www.avaya.com